

## 2030

Mat = C45  
Max T/m = 80  
 $\alpha = 85^\circ - 88^\circ$

835 mm	16,0 kg
415 mm	8,0 kg
805 mm FRAZ. / SECT.	16,0 kg

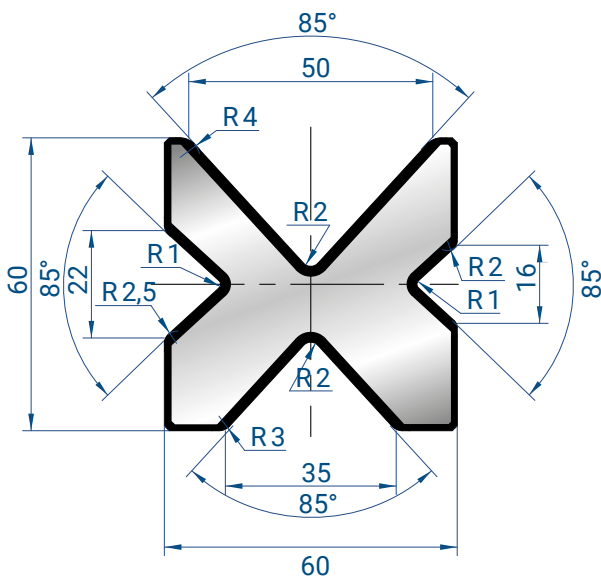

## 2067

Mat = C45  
Max T/m = 80  
 $\alpha = 85^\circ$

835 mm	16,0 kg
415 mm	8,0 kg
805 mm FRAZ. / SECT.	16,0 kg

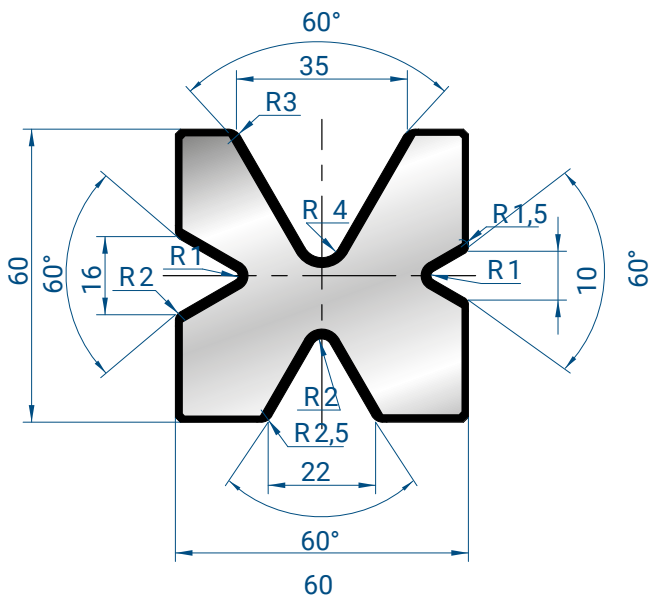

## 2034

Mat = C45  
Max T/m = 60  
 $\alpha = 60^\circ$

835 mm	18,0 kg
415 mm	9,0 kg
805 mm FRAZ. / SECT.	18,0 kg