

PUNZONI - 75° / PUNCHES - 75°

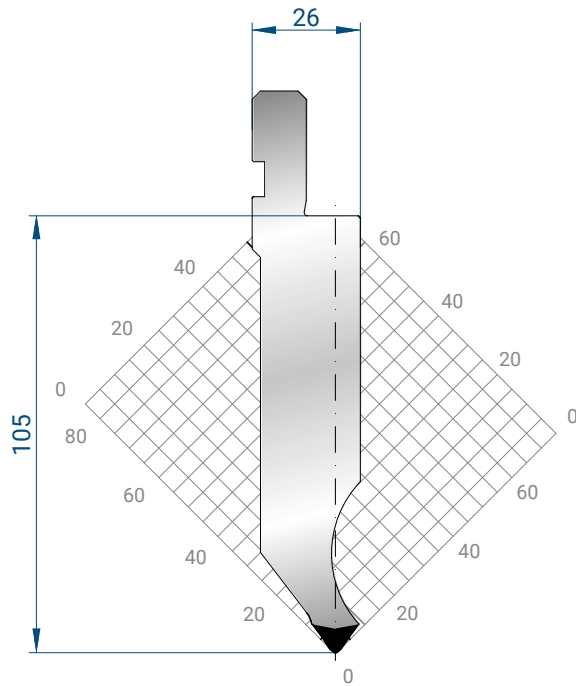

1338

Mat = 42CrMo4
 bonificato/ *tempered*
H = 105
Max T/m = 100
 α = 75°
R = 0.8

835 mm	16,4 kg
415 mm	8,1 kg
805 mm	15,0 kg
FRAZ. / SECT.	

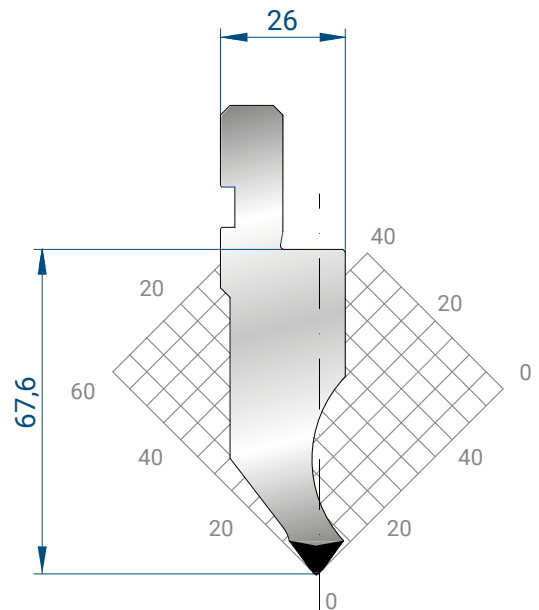

1339

Mat = 42CrMo4
 bonificato/ *tempered*
H = 67,6
Max T/m = 100
 α = 75°
R = 0.8

835 mm	10,5 kg
415 mm	5,2 kg
805 mm	9,7 kg
FRAZ. / SECT.	

PUNZONI - 60° / PUNCHES - 60°

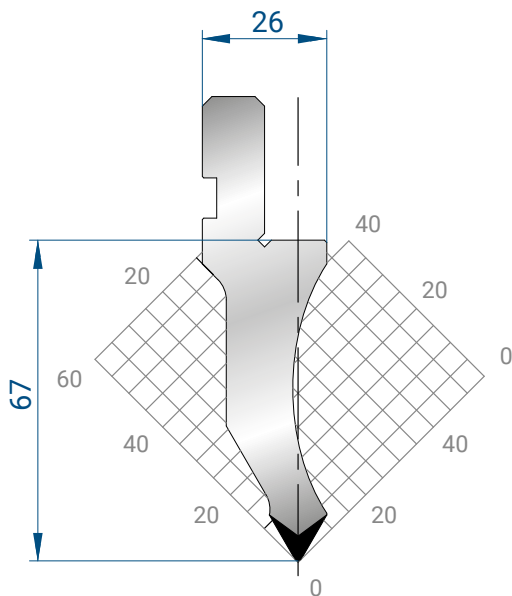

1026

Mat = C45
H = 67.00
Max T/m = 80
 α = 60°
R = 0.8

835 mm	9,0 kg
415 mm	4,0 kg
805 mm	9,0 kg
FRAZ. / SECT.	

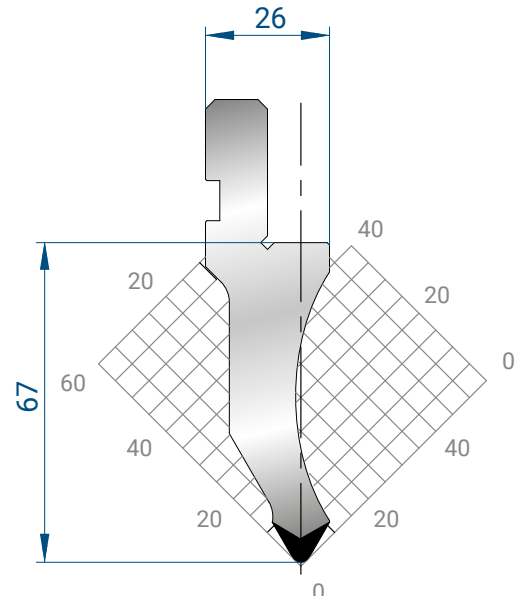

1027

Mat = C45
H = 67.00
Max T/m = 80
 α = 60°
R = 2

835 mm	9,0 kg
415 mm	4,0 kg
805 mm	9,0 kg
FRAZ. / SECT.	