

A Series



STEP 12\"
CNC Touch
Control Unit

Standard Features

1. Y1,Y2,X CNC 3 Axes
2. 210mm Stroke, 410mm Throat Depth
3. STEP 12" CNC Control Unit
4. $\pm 0,03$ accuracy A/C motorized with inverter, back gauge.
5. Manual Promecam punch tool holder
6. MVD special narrow bottom table (European type)
7. Standard punch tools (H: 67, 85°, R:08)
8. Standard die tools (60x60mm, 4 Vee V=16-22-35-50mm, 85°, H:60)
9. High quality and precision linear scales
10. LED illumination on RAM

Optional Features

1. R axis back gauge
2. Sliding front sheet support arms
3. Wide bottom table for Multi Vee dies.
4. Anti-deflection crowning with original Wila wedges
5. AKAS or DSP front laser safety systems
6. Additional back gauge fingers
7. Front laser safety



Standard

X axis back gauge



Standard

Magnetic linear scales (0,005mm precision)

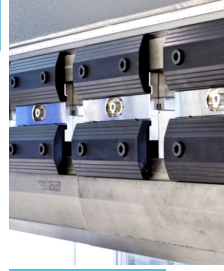

Standard

Manual punch tool holder

410 mm Throat

Stroke
210 mm

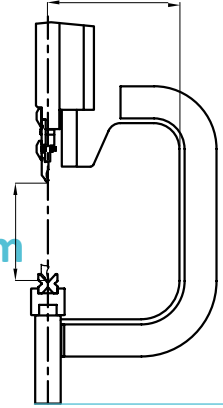

A-Series - Technical Specifications

A Bending Force	Bending Length	Distance between columns	Stroke	Daylight	Throat	Table Height	Machine Dimensions			Speed			Oil tank	Weight	Main motor
	A	B	C	J	D	E	Length x Width x Height (L x W x H)			Approach Speed	Return Speed	Bending Speed	Lt	kg	kW
	mm	mm	mm	mm	mm	mm	mm			mm/s	mm/s	mm/s			
A40	1250	1100	210	465	410	885	3060	2195	2730	150	120	10	95	3400	4
A60	2100	1600	210	465	410	870	3660	2175	2820	160	135	10	170	4290	5,5
	2600	2150	210	465	410	870	4210	2175	2820	160	135	10	170	4790	5,5
A100	2600	2150	210	465	410	905	4220	2230	2855	200	135	10	170	6150	7,5
	3100	2600	210	465	410	905	4670	2230	2855	200	135	10	180	6650	7,5
A135	3100	2600	210	465	410	905	4690	2340	2795	210	130	10	180	7200	11
	3700	3200	210	465	410	905	5290	2340	2850	210	130	10	180	9200	11
	4100	3600	210	465	410	905	5590	2440	2950	210	130	10	180	9750	11
A175	3100	2600	210	465	410	945	4705	2430	2840	180	130	10	180	8400	15
	3700	3200	210	465	410	945	5305	2430	2840	180	130	10	180	9800	15
	4100	3600	210	465	410	945	5600	2530	2950	180	130	10	180	10250	15
A220	3100	2600	210	465	410	880	4720	2415	2805	180	140	10	290	10000	18,5
	3700	3200	210	465	410	930	5320	2415	2805	180	140	10	290	11400	18,5
	4100	3600	210	465	410	930	5620	2515	2905	180	140	10	290	11800	18,5

▶ Controller



2D & 3D touch-screen control from 10" to 19". Off-line software included with 3D version.

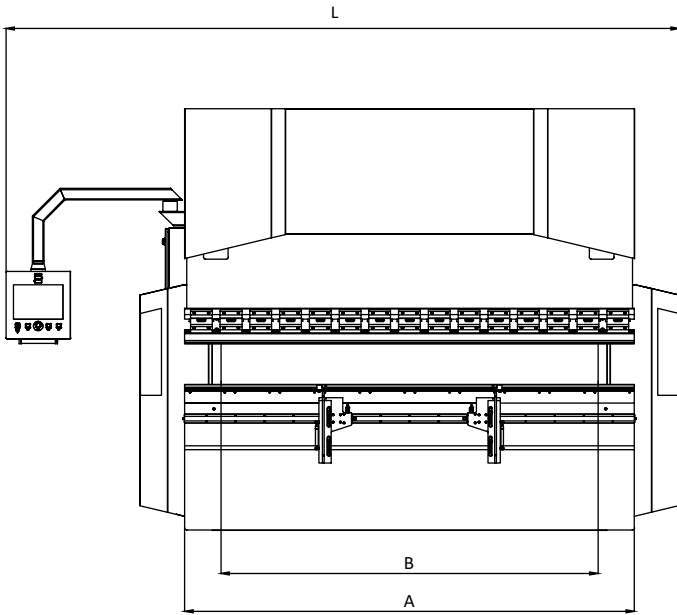
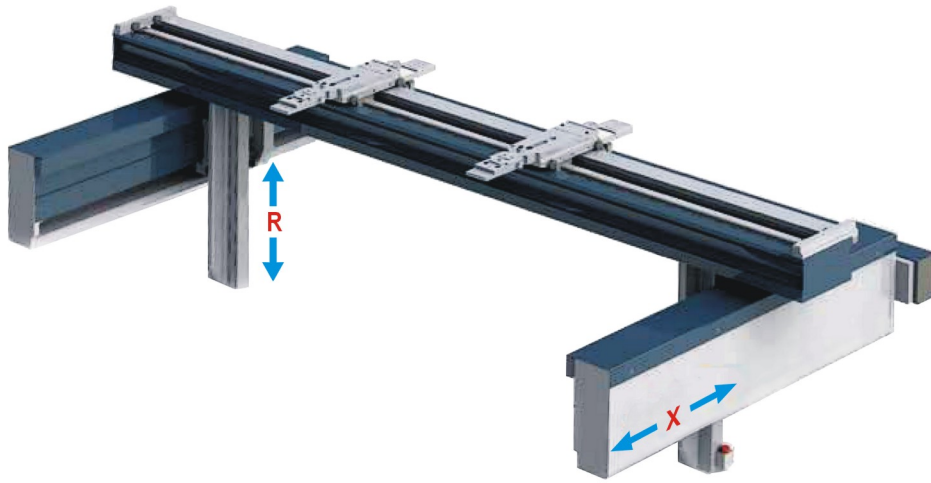

Front view

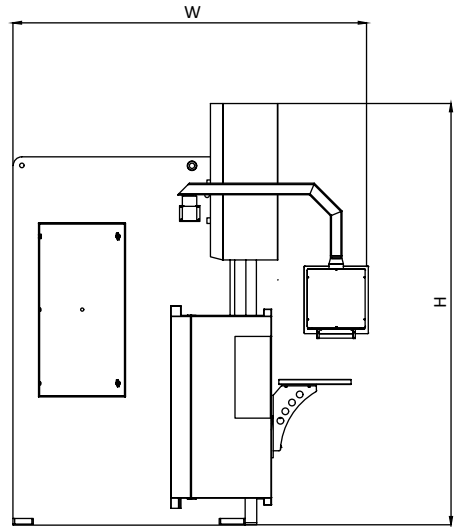

Side view

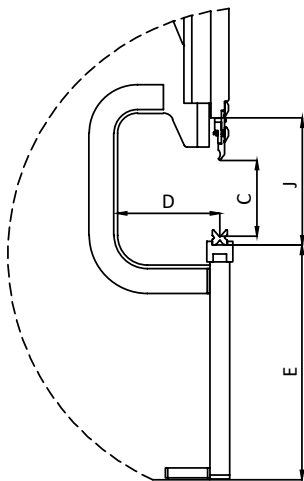

Work zone detail

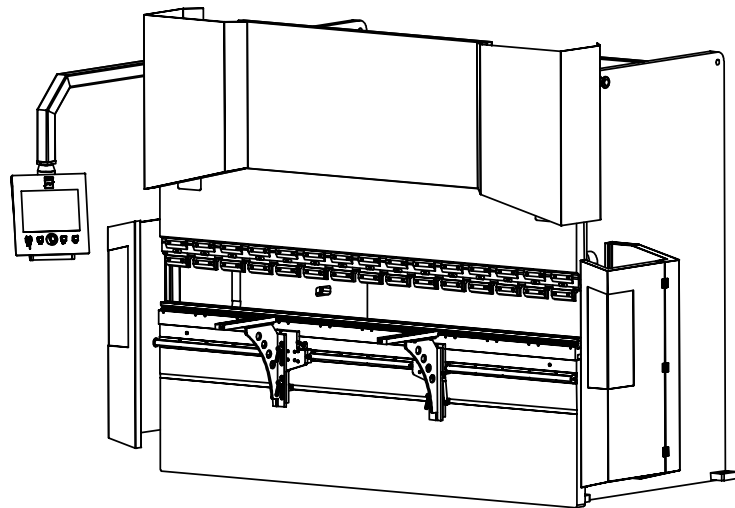

Perspective view